

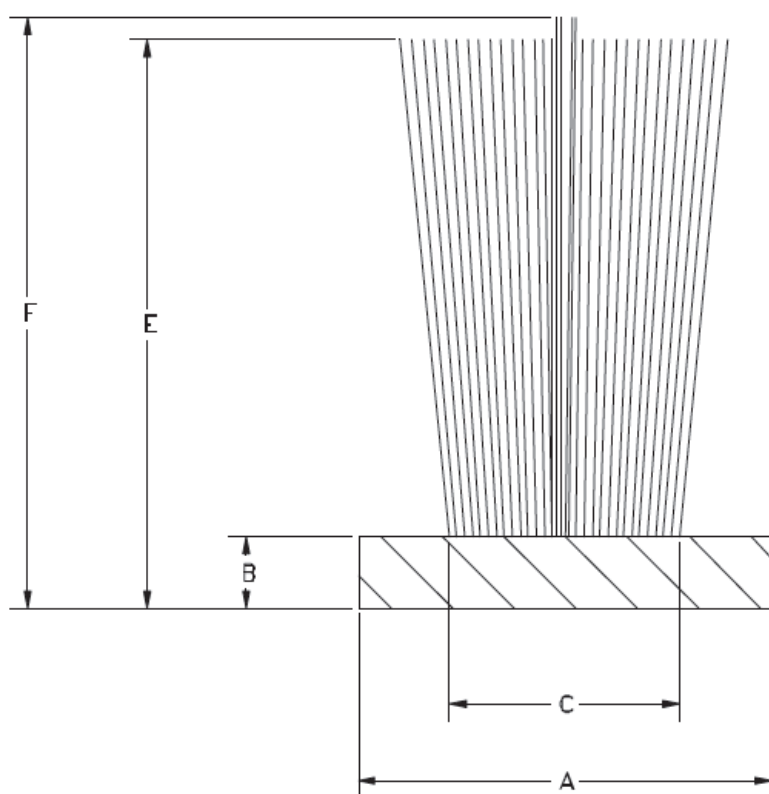

Pile Seals

[UPVc DOORS]

Polybond™ - Powerpile™ - Hotmelt™



Schlegel UK, Henlow Industrial Estate, Henlow Camp, Bedfordshire, SG16 6DS UK
Tel: +44 1462 815500 Fax: +44 1462 811963 email: schlegeluk@grouphomesafe.com www.schlegel.com www.grouphomesafe.com

Schlegel Taliana, S.L., C/L' Anoa,9, P.I.Sta.Margarida, 08223 TERRASSA Barcelona, ESPAÑA
Tel: +34 93 7863264 Fax: +34 93 7312304 e-Mail: schlegeles@schlegel.eu.com www.schlegel.com www.grouphomesafe.com

Schlegel Bvba, Rochesterlaan 4, B-8470 Gistel, Belgium
Tel: +32 59 270 300 Fax: +32 59 270 345 e-Mail: schlegelbe@schlegel.eu.com www.schlegel.co.uk www.grouphomesafe.com

POLYBOND™

Uses and applications:

Weatherstripping for sliding aluminium windows and doors. It is used as insulation to prevent drafts, dust, light and other contaminants coming in from outside through the edges of windows and doors. The product is inserted into the aluminium profile of sliding windows, acting as insulation between their panels.

Description:

Weatherstripping on woven backing covered by a layer of polypropylene which makes it very rigid and durable.

The whole strip is made from 100% polypropylene which prevents mildew formation and is also non-corrosive.

The pile of POLYBOND weatherstripping is siliconized to repel water and is UV stable. It is manufactured

from multi-filament fibres that move independently, guaranteeing an airtight seal even for irregular surfaces. The pile is also subjected to texturizing and heat-setting processes that give it excellent resistance and recovery properties.

Available types:

- PB: Standard pile without fin
 FP: Pile with FIN-SEAL - for high air and water performance.
 Fin is 0.25mm above the pile
 HF: Pile with HIGH-FIN - as FP, for reducing break-off force of sliding elements.
 Fin 2.5mm +/- 0.5mm above the pile
 ZF: Pile with a Z shaped Fin - for increased crush resilience.

Pile, base and fin - polypropylene, non-aging. Pile is silicone.

To order	Backing material = 'POLYBOND'	Backing width 4.8 or 6.9mm	Pile height 4 - 8.5mm	Pile density or fin type
Example	PB	48	450	3P

Pile Height mm	Standard PB 48	Standard PB 69	Finpile PB 48/69	Hi-Fin PB 48/69	Z-Fin PB 48/69
4	400 - 3P	400 - 4P	400 FP	400 HIFIN	400ZFIN
4.5	450 - 3P	450 - 4P	450 FP	450 HIFIN	450ZFIN
5	500 - 3P	500 - 4P	500 FP	500 HIFIN	500ZFIN
5.5	550 - 3P	550 - 4P	550 FP	550 HIFIN	550ZFIN
6	600 - 3P	600 - 4P	600 FP	600 HIFIN	600ZFIN
6.5	650 - 3P	650 - 4P	650 FP	650 HIFIN	650ZFIN
7	700 - 3P	700 - 4P	700 FP	700 HIFIN	700ZFIN
7.5	750 - 3P	750 - 4P	750 FP	750 HIFIN	750ZFIN
8	800 - 3P	800 - 4P	800 FP	800 HIFIN	800ZFIN
8.5	850 - 3P	850 - 4P	850 FP	850 HIFIN	850ZFIN



Schlegel UK, Henlow Industrial Estate, Henlow Camp, Bedfordshire, SG16 6DS UK

Tel: +44 1462 815500 Fax: +44 1462 811963 email: schlegeluk@grouphomesafe.com www.schlegel.com www.grouphomesafe.com

Schlegel Taliana, S.L., C/.L' Anoaia,9, P.I.Sta.Margarida, 08223 TERRASSA Barcelona, ESPAÑA

Tel: +34 93 7863264 Fax: +34 93 7312304 e:Mail: schlegeles@schlegel.eu.com www.schlegel.com www.grouphomesafe.com

Schlegel Bvba, Rochesterlaan 4, B-8470 Gistel, Belgium

Tel: +32 59 270 300 Fax: +32 59 270 345 e:Mail: schlegelbe@schlegel.eu.com www.schlegel.co.uk www.grouphomesafe.com

POLYBOND™

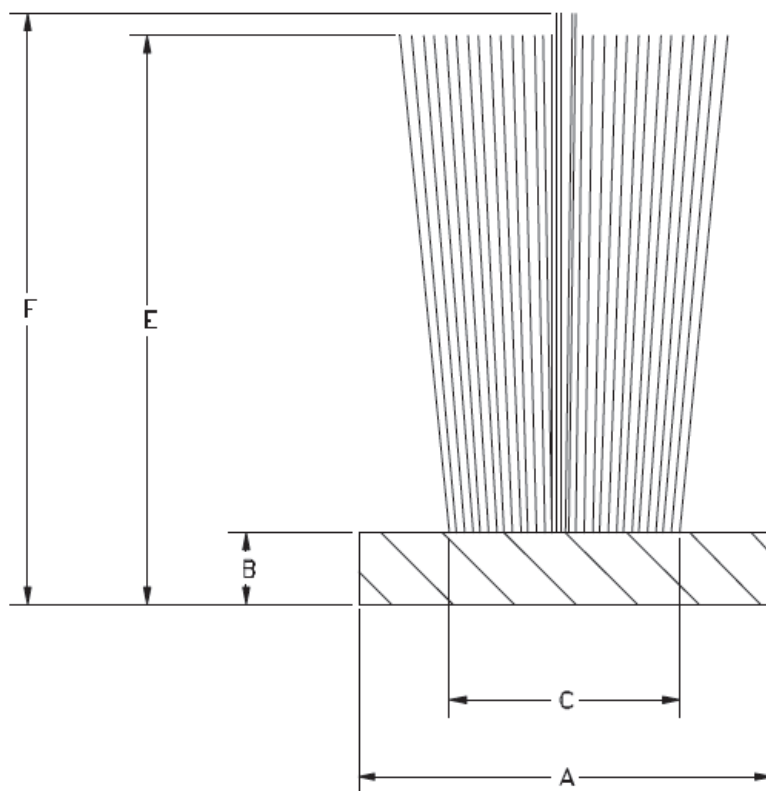

Description	Nominal (mm)	Tolerances (mm)
A = Base width	4.8 - 6.7 - 6.9	+ 0,05 / - 0,20
B = Backing thickness	0,8	+ 0,15
C = Pile base width	1,90	+ 0,20 / - 0,30
D =		
E = Pile height	3.5 -	+ 0,36 / - 0,225
F = Fin height	Pile height + 0.25	+ 0,20



Schlegel UK, Henlow Industrial Estate, Henlow Camp, Bedfordshire, SG16 6DS UK
 Tel: +44 1462 815500 Fax: +44 1462 811963 email: schlegeluk@grouphomesafe.com www.schlegel.com www.grouphomesafe.com

Schlegel Taliana, S.L., C/L' Anoaia,9, P.I.Sta.Margarida, 08223 TERRASSA Barcelona, ESPAÑA
 Tel: +34 93 7863264 Fax: +34 93 7312304 e:Mail: schlegeles@schlegel.eu.com www.schlegel.com www.grouphomesafe.com

Schlegel Bvba, Rochesterlaan 4, B-8470 Gistel, Belgium
 Tel: +32 59 270 300 Fax: +32 59 270 345 e:Mail: schlegelbe@schlegel.eu.com www.schlegel.co.uk www.grouphomesafe.com

Kerf + Pile weatherseal

Product name:	Kerf + Pile weatherseal
Shape Reference nr	Kerf pile weatherseal is made of a rigid barbed profile, with a classic pile weathers with or without centre fin heatwelded onto the profile
Application:	Sliding and sweeping seal in wood windows or doors
Materials:	Profile: Rigid, extruded 100% polypropylene Brush: Woven multifilament Pile Weathersea 100% polypropylene
Properties:	Brush heights from 5mm up to 25mm Brush density: Standard 3P or Dense 4P Optional fin: height flush with brush, or up to 3mm above. Optional fin: standard opaque polypropylene or silent black non woven
Colours:	Profile: Black, Grey, White, Lightoak/Beige, Darkbrown Pile seal: Black, Grey, White, Lightoak/Beige, Darkbrown pile backing colour is white unless otherwise specified
Packaging	Coiled and boxed: Ex 250m/coil 2*250m/box Cut to required length and boxed. Ex: Length = 2150mm, 300pcs/box Quantity depends on brush height
Ordering	Kerf+Pile EX018bis black Pile black 3P density, height H=10mm Fin height FH+12mm Cut to length 2150mm ±5 and boxed

Technical

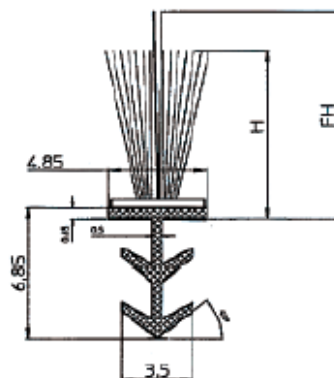

Schlegel UK, Henlow Industrial Estate, Henlow Camp, Bedfordshire, SG16 6DS UK
Tel: +44 1462 815500 Fax: +44 1462 811963 email: schlegeluk@grouphomesafe.com www.schlegel.com www.grouphomesafe.com

Schlegel Taliana, S.L., C./L' Anoaia,9, P.I.Sta.Margarida, 08223 TERRASSA Barcelona, ESPAÑA
Tel: +34 93 7863264 Fax: +34 93 7312304 e:Mail: schlegeles@schlegel.eu.com www.schlegel.com www.grouphomesafe.com

Schlegel Bvba, Rochesterlaan 4, B-8470 Gistel, Belgium
Tel: +32 59 270 300 Fax: +32 59 270 345 e:Mail: schlegelbe@schlegel.eu.com www.schlegel.co.uk www.grouphomesafe.com

POWERPILE™

Uses and applications:

Weatherstripping for aluminium sliding windows and doors, especially designed for improved insertion in the aluminium profiles. Their rigid extruded backing allows for easy insertion in long stretches of aluminium profiles, facilitating the use of automatic insertion machines and thus increasing productivity.

Like the other weatherstripping products for aluminium windows and doors, it is used as insulation to prevent air, water, dust, light and other contaminants from coming in from outside through the gaps around windows and doors. The product is inserted in the aluminium profile of the sliding door or window and acts as insulation between their panels.

Description:

Weatherstripping on a rigid extruded backing (non-woven) which allows quick and easy insertion into the aluminium profiles of sliding windows and doors. The whole strip is made from 100% polypropylene which prevents mildew formation and is also non-corrosive.

The pile of POWER-PILE weatherstripping is siliconized to repel water and is UV stable. It is manufactured from multi-filament fibres that move independently, guaranteeing an airtight seal even for irregular surfaces. The pile is also subjected to texturizing and heat-setting processes that give it excellent resistance and recovery properties.

POWER-PILE types:

- Standard POWER-PILE: weatherstripping on a rigid extruded backing without a plastic fin.
- POWER-PILE with 1 central plastic fin: weatherstripping on a rigid extruded backing with a central plastic fin to provide greater protection from infiltrations.
- POWER-PILE with 3 fins: weatherstripping on a rigid extruded backing with a central plastic fin plus two more plastic fins at the sides to provide superior protection from infiltrations.

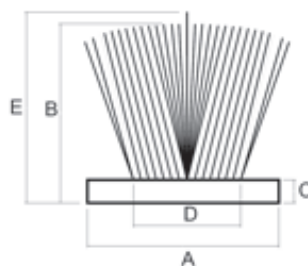

Dimensions: the typical dimensions are:

- A: Width of backing: from 4.80 mm to 9.00 mm, the most common widths being 4.80 mm and 6.90 mm
- B: Height of pile: from 4.00 mm to 15.00 mm, the most common heights being 5.00 mm and 8.00 mm
- C: Thickness of backing: 0,70 mm
- D: Width of pile: 1.98 mm
- E: Height of fin: from 4.00 mm to 15.00 mm, the most common heights being 5.00 mm and 9.00 mm

Schlegel®

Schlegel UK, Henlow Industrial Estate, Henlow Camp, Bedfordshire, SG16 6DS UK

Tel: +44 1462 815500 Fax: +44 1462 811963 email: schlegeluk@grouphomesafe.com www.schlegel.com www.grouphomesafe.com

Schlegel Taliana, S.L., C./L' Anoaia,9, P.I.Sta.Margarida, 08223 TERRASSA Barcelona, ESPAÑA

Tel: +34 93 7863264 Fax: +34 93 7312304 e:Mail: schlegeles@schlegel.eu.com www.schlegel.com www.grouphomesafe.com

Schlegel Bvba, Rochesterlaan 4, B-8470 Gistel, Belgium

Tel: +32 59 270 300 Fax: +32 59 270 345 e:Mail: schlegelbe@schlegel.eu.com www.schlegel.co.uk www.grouphomesafe.com

POWERPILE™

Density and distribution of pile:

Depending on the backing width and the requirements of the window or door, we can manufacture different configurations:

- 4P: 4 pile fibres in one row
- 4PCP: 4 pile fibres in two rows + central fin at the same height as the pile.
- 4PPF: 4 pile fibres in two rows + central fin 0.25 mm higher than the pile height.
- 4PHF+1: 4 pile fibres in two rows + central fin 1.00 mm higher than the pile height.
- 4PHF: 4 pile fibres in two rows + central fin 2.00 mm higher than the pile height.
- 4PHF+3: 4 pile fibres in two rows + central fin 3.00 mm higher than the pile height.

Please enquire about other configurations; we will be pleased to manufacture whatever our customers ask for.

Colours:

Every size is available in a wide range of colours, as detailed below:

Standard Grey (RAL 7045)

Dark Grey (RAL 7039)

Black (RAL 9005)

White (RAL 9003)

Brown (RAL 8028)

Beige (RAL 1011)

Dark Beige (RAL 8008)

Gold (RAL 8025)

Dark Gold (RAL 1032)

Ivory (RAL 1025)

Please enquire about other colours; we will be pleased to manufacture whatever our customers ask for.

Presentation formats:

There are various bobbin formats which can be adapted to best suit the customer's requirements:

- S20 Bobbin: 2 bobbins per box.
The S20 bobbin has an interior diameter of 28 cm and an exterior diameter of 57 cm. Width: 18cm.
Box dimensions: 37 cm (wide) x 57.5 cm (long) x 57.5 cm (high).

Please enquire about other presentation formats; we will be pleased to accommodate your preferences.



Schlegel UK, Henlow Industrial Estate, Henlow Camp, Bedfordshire, SG16 6DS UK

Tel: +44 1462 815500 Fax: +44 1462 811963 email: schlegeluk@grouphomesafe.com www.schlegel.com www.grouphomesafe.com

Schlegel Taliana, S.L., C/.L' Anoaia,9, P.I.Sta.Margarida, 08223 TERRASSA Barcelona, ESPAÑA

Tel: +34 93 7863264 Fax: +34 93 7312304 e:Mail: schlegeles@schlegel.eu.com www.schlegel.com www.grouphomesafe.com

Schlegel Bvba, Rochesterlaan 4, B-8470 Gistel, Belgium

Tel: +32 59 270 300 Fax: +32 59 270 345 e:Mail: schlegelbe@schlegel.eu.com www.schlegel.co.uk www.grouphomesafe.com

HOTMELT™

Uses and applications:

Weatherseals for wooden wardrobes, cupboards and furniture. They are used as insulation to prevent air, dust, light and other contaminants from entering the gaps around wardrobe doors.

The product is stuck to the edge of the wardrobe door panels so it acts as insulation between the panel and the structure of the piece of furniture.

It is recommended for sliding door systems.

Description:

Weatherseal with a woven backing covered in a layer of polypropylene which makes it very rigid and durable.

A layer of "hot melt" type solvent-free block-copolymer laminar adhesive is applied to the backing, protected by a siliconized polyethylene film that is easy to remove at the time of application.

The whole strip, with the exception of the adhesive and the protective film, is made from 100% polypropylene which prevents mildew formation and is also non-corrosive.

The pile of the weatherseal is made from multi-filament fibres that move independently, guaranteeing an airtight seal even for irregular surfaces. The pile is also subjected to texturizing and heat-setting processes that give it excellent resistance and recovery properties.

The weatherseal pile is UV-stable, although the adhesive is not; this means that direct sunlight on the adhesive or backing of the product could lead to early deterioration and loss of its adhesive properties.

Adherence strength: HOT MELT products by Schlegel have a minimum adherence of 16 N-cm (Newton centimetres) measured 24 hours after application of the product, tested at a steady 20°C with relative humidity of 50%.

The method used for testing adherence is a 180° Extraction Test. PDF

Assembly:

the surface onto which the product is to be applied must be completely clean and free from dust, grease or any other contaminant. The application surface should also be completely smooth and pore-free.

As this is a Hot Melt-type product, in order to prevent it from deteriorating the optimum working conditions should be:

- Temperature: 25°C +/-10°C
- Humidity: 50% +/-20°C

The application surface should be stabilized to the above working conditions at least 12 hours before and 12 hours after application.



Schlegel UK, Henlow Industrial Estate, Henlow Camp, Bedfordshire, SG16 6DS UK
Tel: +44 1462 815500 Fax: +44 1462 811963 email: schlegeluk@grouphomesafe.com www.schlegel.com www.grouphomesafe.com

Schlegel Taliana, S.L., C/.L' Anoaia,9, P.I.Sta.Margarida, 08223 TERRASSA Barcelona, ESPAÑA
Tel: +34 93 7863264 Fax: +34 93 7312304 e:Mail: schlegeles@schlegel.eu.com www.schlegel.com www.grouphomesafe.com

Schlegel Bvba, Rochesterlaan 4, B-8470 Gistel, Belgium
Tel: +32 59 270 300 Fax: +32 59 270 345 e:Mail: schlegelbe@schlegel.eu.com www.schlegel.co.uk www.grouphomesafe.com

HOTMELT™

Dimensions: the typical dimensions are:

- A: Width of backing: from 4.80 mm to 40 mm, the most common widths being 6.90 mm and 9.50 mm
- B: Height of pile: from 4.00 mm to 32.50 mm, the most common heights being 5.00 mm and 9.00 mm
- C: Thickness of backing: 0.65 mm, 0.80 mm and 0.95 mm
- D: Width of woven pile: from 1.98 mm to 35.00 mm, the most common widths being 1.98 mm and 2.90 mm

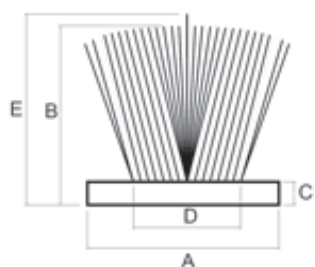

Colours:

Every size is available in a wide range of colours, as detailed below:

- Standard Grey (RAL 7045)
- Dark Grey (RAL 7039)
- Black (RAL 9005)
- White (RAL 9003)
- Brown (RAL 8028)
- Beige (RAL 1011)
- Dark Beige (RAL 8008)
- Gold (RAL 8025)
- Dark Gold (RAL 1032)
- Ivory (RAL 1025)

Please enquire about other colours; we will be pleased to manufacture whatever our customers ask for.

Capacities:

The number of metres per bobbin depends on the dimensions of the weatherseal.

For example, a HOT MELT weatherseal with a backing width of 6.90 mm and a pile height of 5.00 mm would give 375 metres per bobbin. Reference: HM-69-500-3P

Presentation formats:

For a weatherseal height of up to 9.00 mm, the product comes in 4 bobbins per box. Box dimensions: 31 cm (wide) x 62 cm (long) x 46 cm (high)

For weatherseals higher than 9.00 mm, to prevent the pile from being squashed, the product is supplied in 2 bobbins per box. Box dimensions: 37.5 cm (wide) x 58 cm (long) x 58 cm (high)

Please enquire about other presentation formats; we will be pleased to accommodate your preferences.

Storage and use-by dates:

HOT MELT products must be stored in their original packaging at between 0°C and 40°C, 20°C being the optimum storage temperature for the adherent properties of the product to be kept in a perfect condition.

We recommend you use the product within 12 months of the date shown on the packaging.

Make sure you turn your stock over regularly.



Schlegel UK, Henlow Industrial Estate, Henlow Camp, Bedfordshire, SG16 6DS UK
Tel: +44 1462 815500 Fax: +44 1462 811963 email: schlegeluk@grouphomesafe.com www.schlegel.com www.grouphomesafe.com

Schlegel Taliana, S.L., C/L' Anoaia,9, P.I.Sta.Margarida, 08223 TERRASSA Barcelona, ESPAÑA
Tel: +34 93 7863264 Fax: +34 93 7312304 e:Mail: schlegeles@schlegel.eu.com www.schlegel.com www.grouphomesafe.com

Schlegel Bvba, Rochesterlaan 4, B-8470 Gistel, Belgium
Tel: +32 59 270 300 Fax: +32 59 270 345 e:Mail: schlegelbe@schlegel.eu.com www.schlegel.co.uk www.grouphomesafe.com