



**SCHLEGEL UK**

Henlow Industrial Estate,  
 Henlow Camp,  
 Bedfordshire,  
 SG16 6DS  
 Tel: +44 (0) 1462 815500  
 Fax: +44 (0) 1462 638800  
 E-mail: schlegeluk@schlegel.eu.com

\* Registered trademark of Schlegel Systems Inc.

## AQUAMAC\* 76

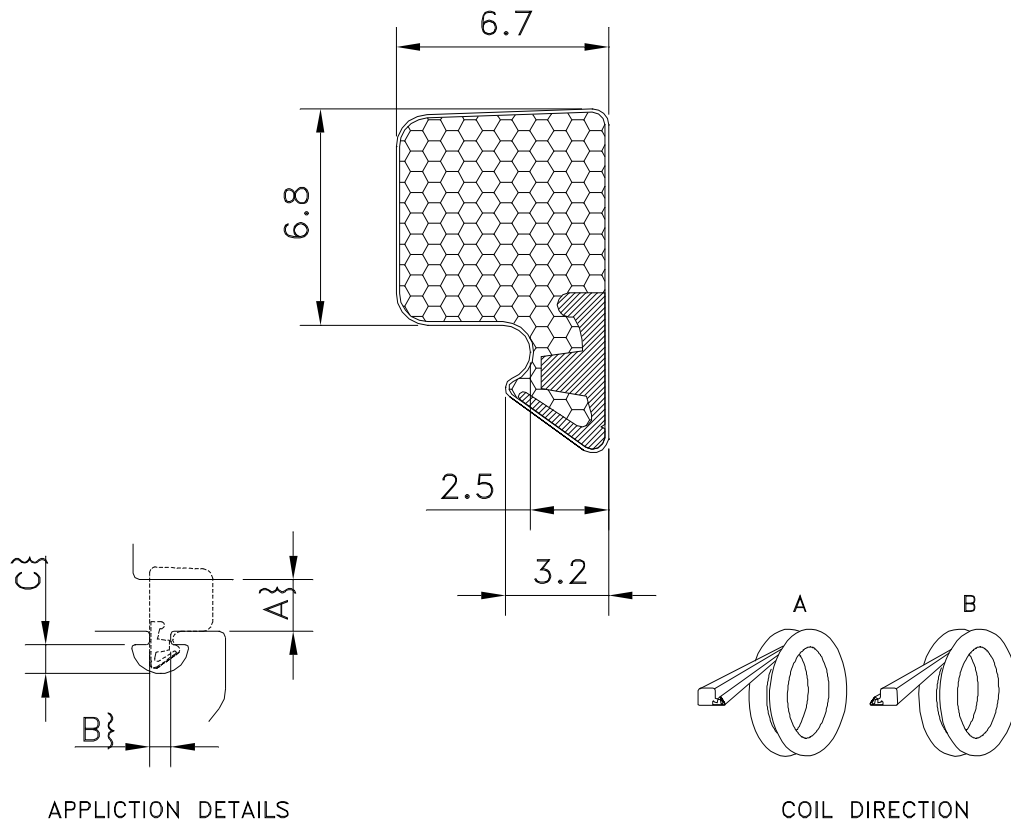

### TECHNICAL SPECIFICATION

- A, SEAL GAP. 3.4mm MIN TO 5.4mm MAX
- B, RETENTION SLOT THROAT. 2.0mm NOMINAL
- C, MINIMUM POCKET DEPTH 2.8mm

PART NUMBER	COLOUR	METRES/COIL	COIL DIRECTION	APPLICATION
02276003	WHITE	200	A	GLAZING SEAL
02276005	BLACK	200	A	GLAZING SEAL

60267-0B



BS7386 : 1990  
 Licence NO. KM  
 30928

Schlegel UK is a division of Schlegel Limited, Registration No. 3471668 Reg.  
 Office : Hillside House, 32 Hampstead High St, London, NW3 1QD



Certification No.  
 FM 15052