

Schlegel Weather Seal Range



Technical Data Sheet
Product = QLON 3034

Testing undertaken to ISO 9001/2000; BSI Registration FM15052 (since 29/07/1992)

Specification			
Characteristic	Value	Units	Test Method
ACLD (Aged Compression Load Deflection)	4.0 – 10.0 N/100mm	Newtons per 100mm length	In House
Compression Set	>20% set after 24hours (50% compression) @ 70°C	% Recovery mm	In House
Dimensions		mm	In House

BS EN 12365:2003 Part 4 Classification W 2 4 5 6 6 (Please note – ‘recovery after aging’ is not applicable to this assessment)

Drawing Detail

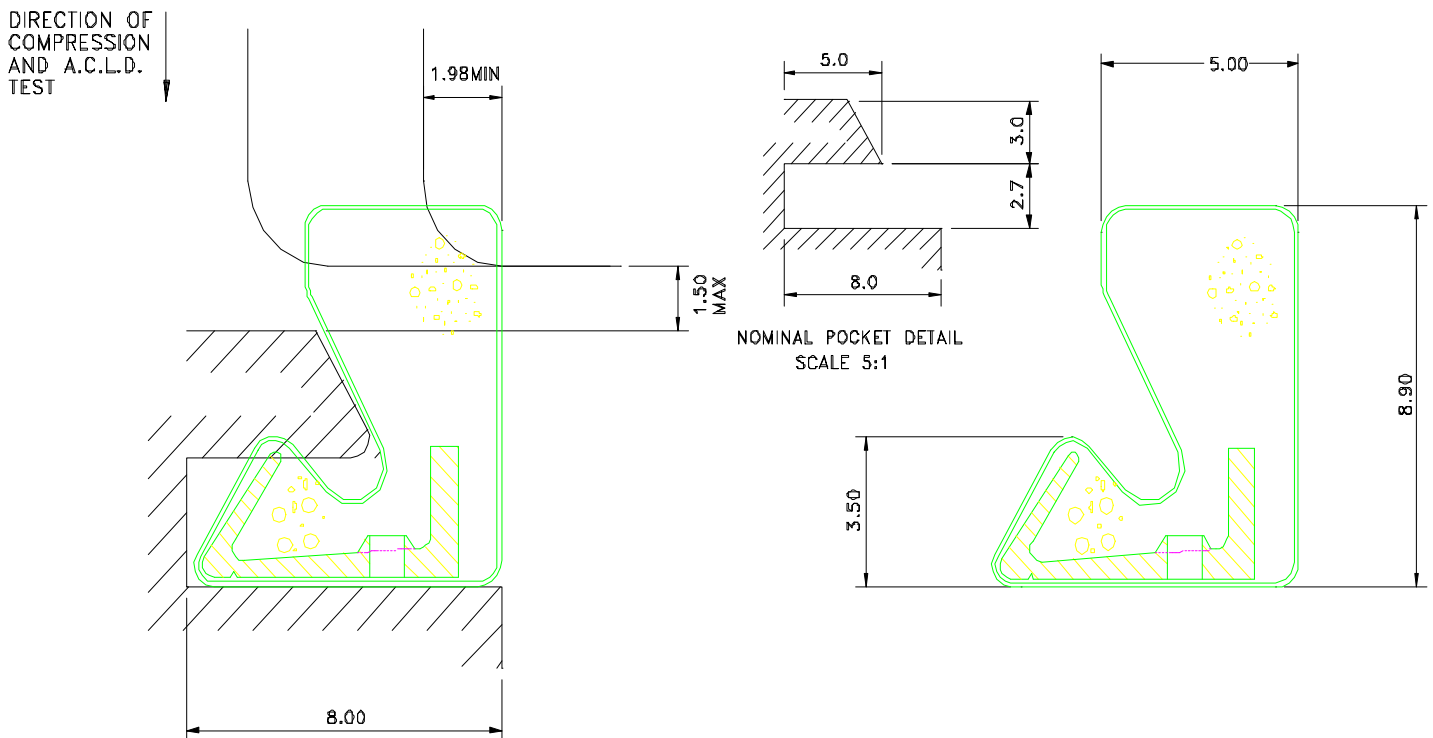

- NOTES:-
- 1, DIMENSIONS ARE NOMINAL, UNLESS OTHERWISE STATED
 - 2, DIMENSIONS SUBJECT TO DEVELOPMENT TRIALS
 - 3, KERF SLOT SIZE TO BE 2.7±0.2mm WIDE, AND 5.0mm MINIMUM IN DEPTH

Schlegel UK, Henlow Industrial Estate, Henlow Camp, Bedfordshire, SG16 6DS

Phone: +44 1462 815500 Fax: +44 1462 811963

e:Mail: schlegeluk@schlegel.eu.com

Material / Components

- Exterior Liner** = Poly-ethylene, low friction, UV stable
 Exterior Liner Melt Index = approx. 0,85 g/10 min at 190 °C., 2,16 kg mass – 2.0MI
Hard Foot / insert = Poly-propylene OR Glass fibre roving (part specific) Poly-propylene back / TPE foot for exposed barb products
Foam Core = H/R Poly-Urethane, exhibiting excellent memory performance over wide temp range

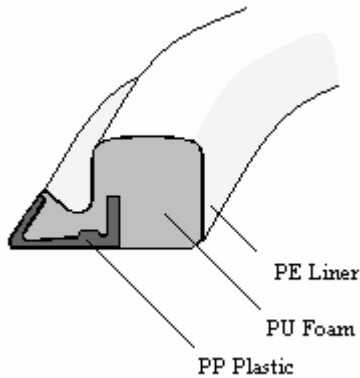

Nominal Value of Thermal Conductivity

Low density P.E (used for the outer skin) is advised at 0.33 W/mKelvin
 P.U.foam at a density of 70Kg / cubic mtr having a conductivity of 0.05 W/mKelvin
A proposed nominal value for all our seals = 0.06W/mKelvin.

CO-EFFICIENT OF FRICTION OF LINER (QLON SURFACE)

COF of Quality 163.00; film against steel; DIN EN ISO 8295				
	95 µm	140 µm		
Static	0.241	0.146		
Kinetic	0.251	0.157		

Fire Rating

These seals are NOT fire resistant but can be used in conjunction with intumesant strips as 'smokeseals' – Smoke seal application testing is undertaken on the whole door set and as such we are unable to provide information on individual seals

Nominal Values for Sound Reduction Weighting

- $R_w(C, C_{tr}) = 32 (-1; -3)$ dB
 $R_w(C, C_{tr}) = 22 (-1; -1)$ dB
 $R_w(C, C_{tr}) = 16 (-1; 0)$ dB
 $R_w(C, C_{tr}) = 29 (0; -2)$ dB

Packaging Specification

GMBH Packaging 2 Coils per box; Nominal ???m / Coil
 Coil = 790 OD – 570 ID; Box = 775*775*380mm

Schlegel UK, Henlow Industrial Estate, Henlow Camp, Bedfordshire, SG16 6DS
 Phone: +44 1462 815500 Fax: +44 1462 811963
 e:Mail: schlegeluk@schlegel.eu.com

Part Numbers

02330340	QL 3034 WHT 400M COIL	CL	400
02330341	QL 3034 BRZ 400M COIL	CL	400
02330342	QL 3034 BLK 400M COIL	CL	400
02330343	QL 3034 BGE 400M CL	CL	400
02330344	QL 3034 D/GRY M5 400M CL	CL	400
02330345	QL 3034 L/OAK 400M COIL	CL	400
02330346	QL 3034 L/GRY 400M COIL	CL	400
02330347	QL 3034 S/GRY 400M COIL	CL	400
02330349	QL 3034 CH BRN 400M CL	CL	400
02330440	QL 3034 WHT 200M COIL	CL	200
02330441	QL 3034 BRZ 200M COIL	CL	200
02330442	QL 3034 BLK 200M CL	CL	200
02330445	QL 3034 L/OAK 200m CL	CL	200

BBA Report

CRITERIA	B.B.A. 345/1 1993	B.B.A. Report 1990	Comments
TENSILE STRENGTH AFTER AGEING	< 25% REDUCTION AFTER 10 DAYS AT 70 ⁰ C	0% REDUCTION AFTER 28 DAYS	Q-Lon Exceeds the requirement
ELONGATION AT BREAK AFTER AGEING.	< 25% REDUCTION	> 5% REDUCTION AFTER 28 DAYS.	Q-Lon Exceeds the requirement
HARDNESS CHANGE AFTER AGEING	< 25% REDUCTION AFTER 10 DAYS AT 70 ⁰ C	COMPRESSION FORCE CHANGED BY 5% AFTER 28 DAYS	Q-Lon Exceeds the requirement
TEAR RESISTANCE	RAW MATERIAL TEST ONLY	NO ASSESSMENT	
DEFLECTION RECOVERY 24HRS @ 23 ⁰ C	> 75% RECOVERY	91.67% RECOVERY @ 70 ⁰ C	Q-Lon Exceeds the requirement
24hrs @ -15 ⁰ C	> 75% RECOVERY (LESS THAN 25% SET	100% RECOVERY	
14DAYS @ 55 ⁰ C	>25% RECOVERY	NOT ASSESSED	
OZONE RESISTANCE		NOT ASSESSED & NOT AFFECTED BY OZONE	This criteria is a limitation of Rubber / E.P.D.M.
DIMENSIONAL STABILITY	HEAT REVERSION < 2%	DIMENSIONAL STABILITY 0.01%	Q-Lon Exceeds the requirement

The B.P.F. have reviewed the 345/1 document and are shortly to publish a revision. The revisions take account of current European draft standards for seals and will most likely include the following changes.

1. Test methods will not be limited to raw material assessment.
2. The test methods will allow the seal performance to be graded as opposed to minimum levels being specified. The system is intended to allow an appropriate seal to be specified for an application. Minimum performances are still assessed via the functionality tests of the complete window / door unit.

Schlegel UK, Henlow Industrial Estate, Henlow Camp, Bedfordshire, SG16 6DS

Phone: +44 1462 815500 Fax: +44 1462 811963

e:Mail: schlegeluk@schlegel.eu.com

Performance Benefits Summary

Excellent memory – Returns to original shape after compression

Stability – Low/no stretch gained by GF internal cord or insert

Easily compressed – Low compression forces, Unaffected by temp variance (tested to -30oC to +70oC)

Acoustic performance – Independent testing and comparison data available

Paint and Stain Proof – Properties un-affected by standard paints and stains

Stabilised – Unaffected by rot, Fungi, UV light or Ozone.

Colour – Wide range of available options (bronze, white, black, greys, etc)

Jointing – Can be joined with silicone sealant or welded in situ'

Patented. – Selling Seals to the industry for over 30 years

Schlegel UK, Henlow Industrial Estate, Henlow Camp, Bedfordshire, SG16 6DS

Phone: +44 1462 815500 Fax: +44 1462 811963

e:Mail: schlegeluk@schlegel.eu.com