



**SCHLEGEL UK**

Henlow Industrial Estate,  
 Henlow Camp,  
 Bedfordshire,  
 SG16 6DS  
 Tel: +44 (0) 1462 815500  
 Fax: +44 (0) 1462 638800  
 E-mail: schlegeluk@schlegel.eu.com

\* Registered trademark of Schlegel Systems Inc.

## Q-LON\* 4465

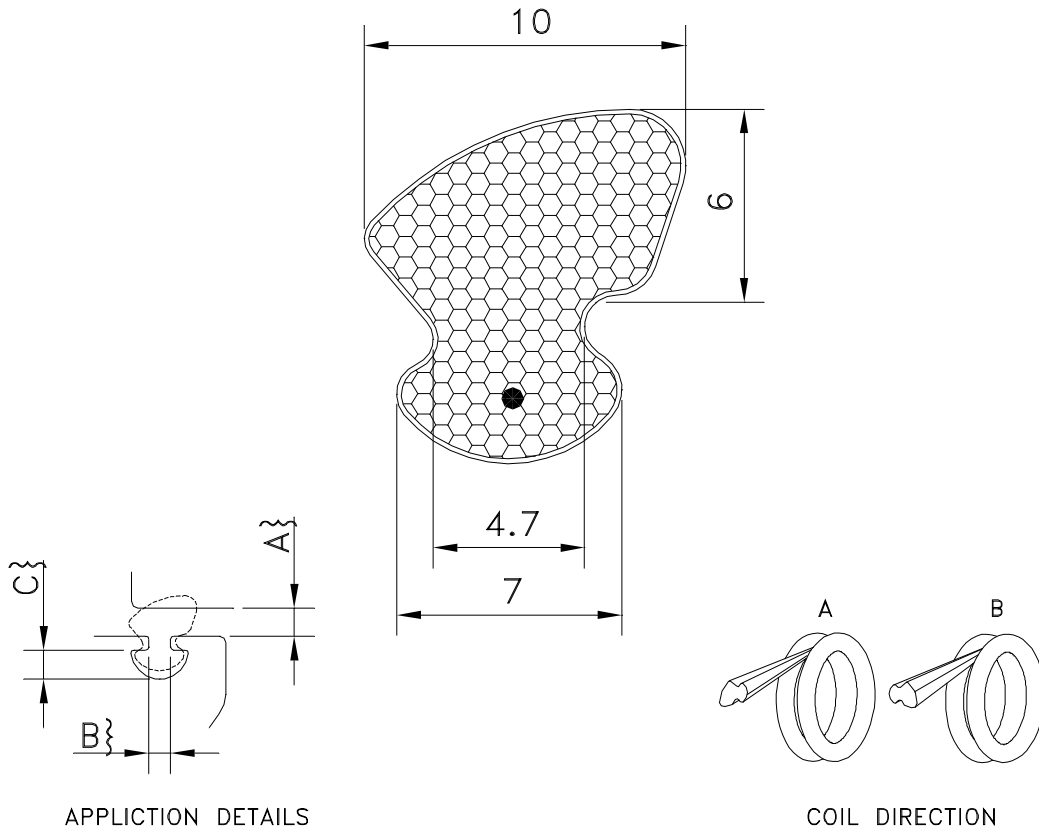

### TECHNICAL SPECIFICATION

- A, SEAL GAP. 3.0mm MIN TO 4.8mm MAX
- B, RETENTION SLOT THROAT. 4.2mm NOMINAL
- C, MINIMUM POCKET DEPTH 3.5mm

| PART NUMBER | COLOUR | METRES/COIL | COIL DIRECTION | APPLICATION |
|-------------|--------|-------------|----------------|-------------|
| 02760002    | WHITE  | 250         | A              | WEATHERSEAL |
| 02760003    | BRONZE | 250         | A              | WEATHERSEAL |
| 02760004    | BLACK  | 250         | A              | WEATHERSEAL |
| 02760006    | GREY   | 250         | A              | WEATHERSEAL |
|             |        |             |                |             |
|             |        |             |                |             |

60222-0B



BS7386 : 1990  
 Licence NO. KM  
 30928

Schlegel UK is a division of Schlegel Limited, Registratio n No. 3471668 Reg.  
 Office : Hilldown House, 32 Hampstead High St, London, NW3 1QD



Certification No.  
 FM 15052