



SCHLEGEL UK

Henlow Industrial Estate,
 Henlow Camp,
 Bedfordshire,
 SG16 6DS
 Tel: +44 (0) 1462 815500
 Fax: +44 (0) 1462 638800
 E-mail: schlegeluk@schlegel.eu.com

* Registered trademark of Schlegel Systems Inc.

Q-LON* 9154

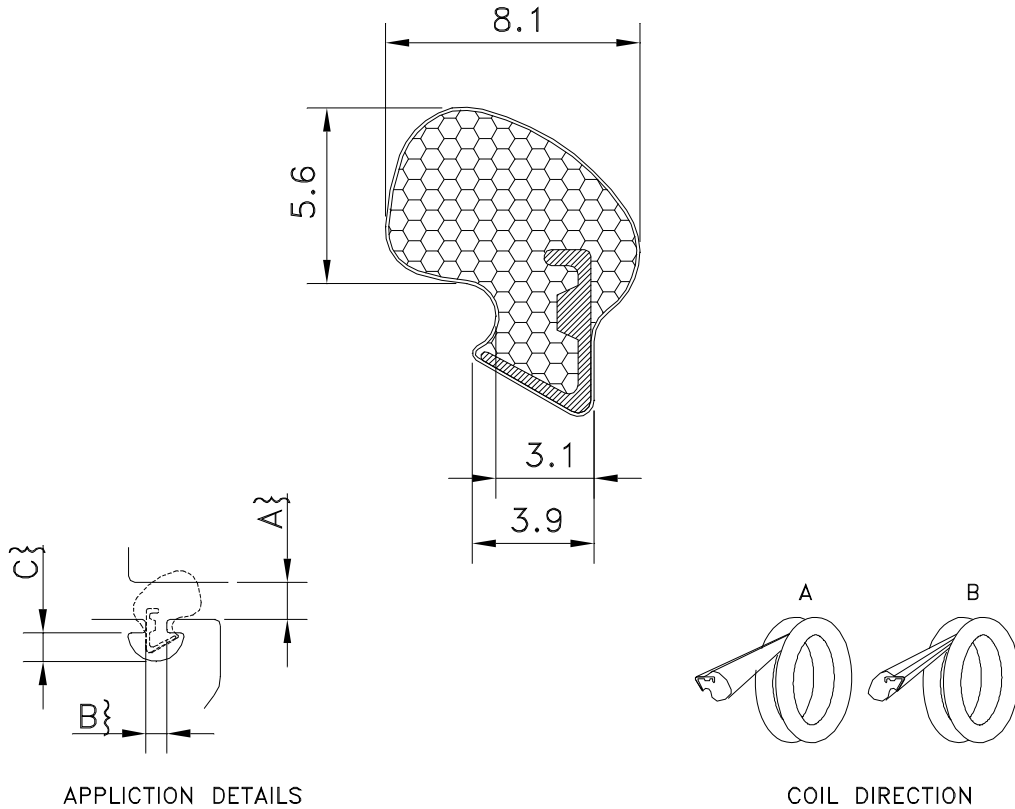

TECHNICAL SPECIFICATION

- A, SEAL GAP. 2.8mm MIN TO 4.5mm MAX
- B, RETENTION SLOT THROAT. 3.2mm NOMINAL
- C, MINIMUM POCKET DEPTH 3.5mm

| PART NUMBER | COLOUR | METRES/COIL | COIL DIRECTION | APPLICATION |
|-------------|--------|-------------|----------------|-------------|
| 02791540 | WHITE | 300 | A | WEATHERSEAL |
| 02791541 | BRONZE | 300 | A | WEATHERSEAL |
| 02791542 | BLACK | 300 | A | WEATHERSEAL |
| | | | | |
| | | | | |

60246-0B



BS7386 : 1990
 Licence NO. KM
 30928

Schlegel UK is a division of Schlegel Limited, Registratio n No. 3471668 Reg.
 Office : Hillside House, 32 Hampstead High St, London, NW3 1QD



Certification No.
 FM 15052