



**SCHLEGEL UK**

Henlow Industrial Estate,  
 Henlow Camp,  
 Bedfordshire,  
 SG16 6DS  
 Tel: +44 (0) 1462 815500  
 Fax: +44 (0) 1462 638800  
 E-mail: schlegeluk@schlegel.eu.com

\* Registered trademark of Schlegel Systems Inc.

**Q-LON\* 9504**

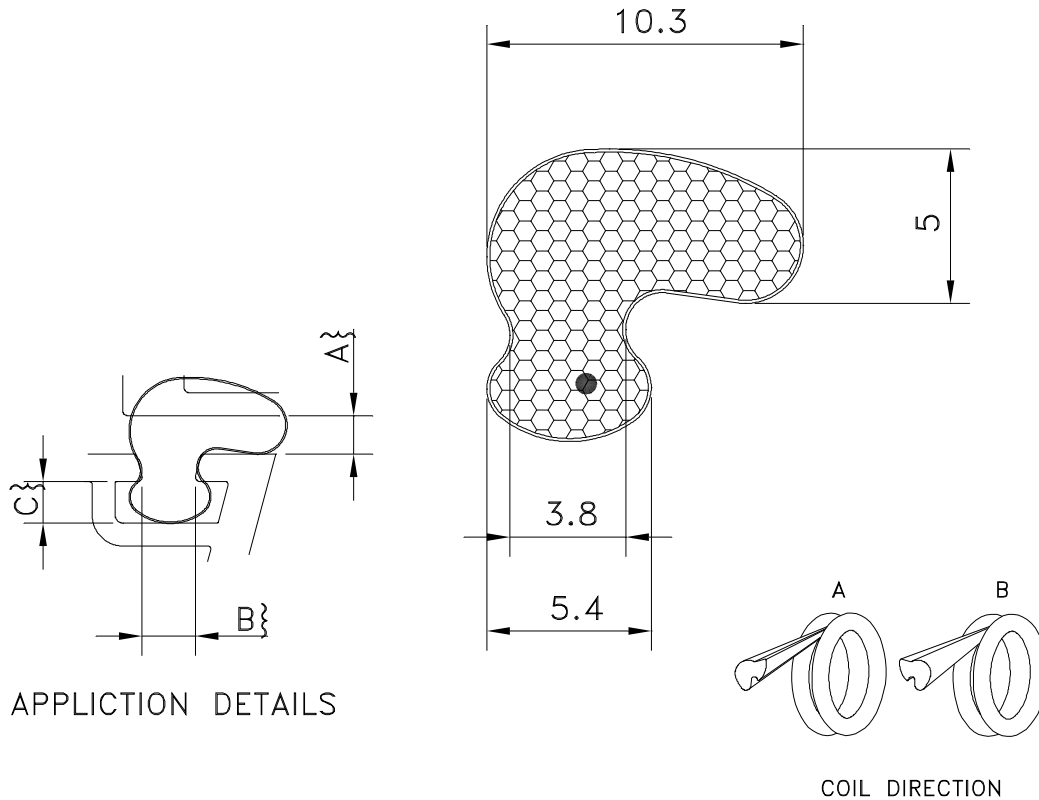

**TECHNICAL SPECIFICATION :-**

- A. SEAL GAP:- 2.5mm MIN TO 4.0mm MAX
- B. RETENTION SLOT THROAT:- 3.5mm NOMINAL
- C. MINIMUM POCKET DEPTH 3.0mm

PART NUMBER	COLOUR	METRES/COIL	COIL DIRECTION	APPLICATION
02795040	WHITE	300	A	WEATHERSEAL
02795041	BRONZE	300	A	WEATHERSEAL
02795042	BLACK	300	A	WEATHERSEAL

60507-0C



BS7386 : 1990  
 Licence NO. KM  
 30928

Schlegel UK is a division of Schlegel Limited, Registratio n No. 3471668 Reg.  
 Office : Hillsdow House, 32 Hampstead High St, London, NW3 1QD



Certification No.  
 FM 15052