



SCHLEGEL UK

Henlow Industrial Estate,
 Henlow Camp,
 Bedfordshire,
 SG16 6DS
 Tel: +44 (0) 1462 815500
 Fax: +44 (0) 1462 638800
 E-mail: schlegeluk@schlegel.eu.com

* Registered trademark of Schlegel Systems Inc.

Q-LON* 9667/8

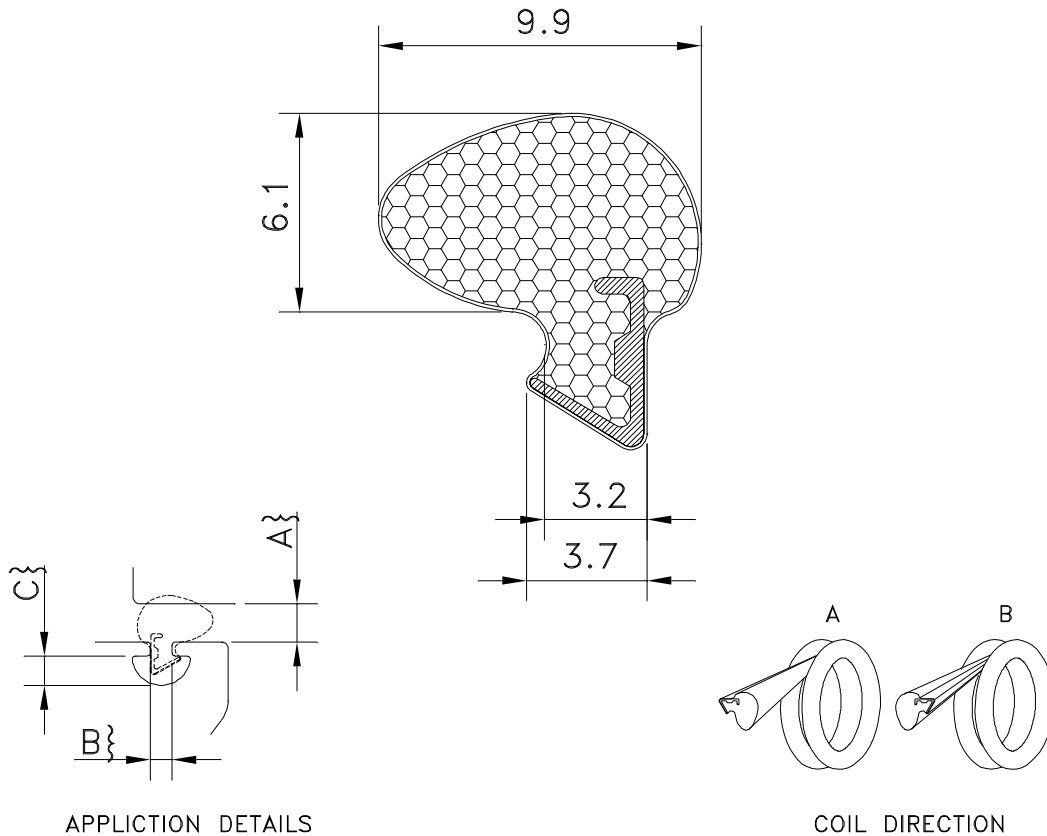

TECHNICAL SPECIFICATION

- A, SEAL GAP. 3.0mm MIN TO 4.9mm MAX
- B, RETENTION SLOT THROAT. 3.2mm NOMINAL
- C, MINIMUM POCKET DEPTH 2.5mm

PART NUMBER	COLOUR	METRES/COIL	COIL DIRECTION	APPLICATION
02796670	WHITE	300	A	WEATHERSEAL
02796671	BRONZE	300	A	WEATHERSEAL
02796672	BLACK	300	A	WEATHERSEAL
02796680	WHITE	300	A	GLAZING SEAL
02796681	BRONZE	300	A	GLAZING SEAL
02796682	BLACK	300	A	GLAZING SEAL

60245-0B



BS7386 : 1990
 Licence NO. KM
 30928

Schlegel UK is a division of Schlegel Limited, Registratio n No. 3471668 Reg.
 Office : Hillsgate House, 32 Hampstead High St, London, NW3 1QD



Certification No.
 FM 15052